

Vignelli Center for Design Studies Annual Report 2023

Contents

Summary	4
Impact Statement	7
Goals of the Vignelli Center	11
Overview	14
Framework	15
Archives	29
Communications	40
Initiatives	42
Programming	49
Photos	101
Spotlight Friends	121
Notes	127
Appendix	147

Summary 2023

Impact

We welcomed new friends to the Center and we visited old ones. In this year alone our events and endeavors presented the Vignelli presence from New York City to Milan and from Tel Aviv to Istanbul, Basel and beyond.

Reza Aliabadi, became the Center's first Designer in Residence, marking an important milestone for the Center.

Looking Ahead

Hands-on outdoor museum consisting of 14 locations across RIT's Henrietta campus. The stations have been designed following the Vignelli ethos by renown architect, Reza Aliabadi, who has been working closely with Director, Josh Owen, to mentor 14 industrial design students each individually responsible for a universal theme assigned to each station.

Significant grant awarded in concert with the RIT University Archives to restore the historic Harry Bertioia Dandelion sculptures constellation originally introduced in the 1964 Worlds Fair Kodak Pavilion in NYC.

These large-scale and extremely public projects will show the Center's commitment to community engagement, design history and cultural production beyond the walls of the Center's building.

Vignelli Archive Access

- Answered 208 inquiries from 14 different countries
- Provided over 4000 archival artifacts to researchers
- Hosted 12 researchers in person
- Taught 16 class sessions with RIT's photo, 2D/3D Foundations, Interior Design, Industrial Design, New Media, Graphic Design, Visual Communications, and Museum Studies

Goals

Education

Programming
Research
Collaboration

Preservation

Collecting
Dissemination

Advocacy

Communication
Public Good
Global Reach

Key Stakeholders

David Munson
Lady Helen Hamlyn
Rochester Institute of Technology
RIT University Archives
Corning Museum of Glass



Summer Design Workshop Glasswork

Melissa Dawson



Metaproject 14

Project by Sydney Neff



*Names included in the full report

Thank you!

We are so grateful to our incredible Vignelli Center family—students, faculty, friends, donors, sponsors, and community—for your unwavering support. Your dedication fuels our vision, shaping the future of design and education.

metaproject 13

LAZZONI + RIT



2023 Impact

Together Again

2023 brings the return of the Center operating at full strength. With many of the restrictions associated with the pandemic behind us, we focused on once again bringing people into the Center to witness the Vignelli legacy in person. Several Design Conversations, in partnership with Design Milk, were held in Wegmans' Theater to an audience filled with students, faculty, and community members alike. The third-annual Beyond Fashion show, themed around the Vignellis' love for the grid, was marked by the most student participation in its history. After the previous years' success, the second Summer Design Workshop was held in collaboration with the Corning Museum of Glass, with another year of spectacular output. Metaproject 14 was completed alongside Designer in Residence Reza Aliabadi. Participants in Metaproject 13 also made their return to NYC Design Week to present their work. Overall, the year found the Center making strides to bring the community together again: off Zoom and in person.

Advancing Goals

Within the pages of this document, you will read about our accomplishments and milestones. We welcomed new friends to the Center and we visited old ones. In this year alone our events and endeavors presented the Vignelli presence from New York City to Milan and from Tel Aviv to Istanbul, Basel and beyond. Our many projects continued to expand our mission globally with milestones through notable projects and partnerships following our goals of education, preservation, and advocacy.

Looking Ahead

We have much to look forward to. With many exciting projects in play and eyes towards expanding our archives staff, we need our friends more than ever. We continue to lead by design with the Vignelli Center for Design Studies shining as a beacon and a nexus for discourse that sees education as a long-term pathway to peace and the better world we all seek.

—Josh Owen, Vignelli Center Director

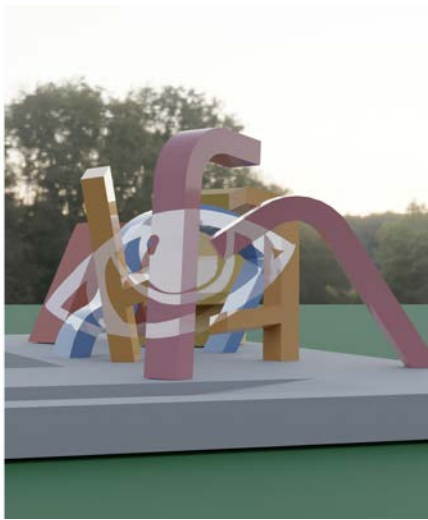

Highlights 2023



Goals of the Vignelli Center

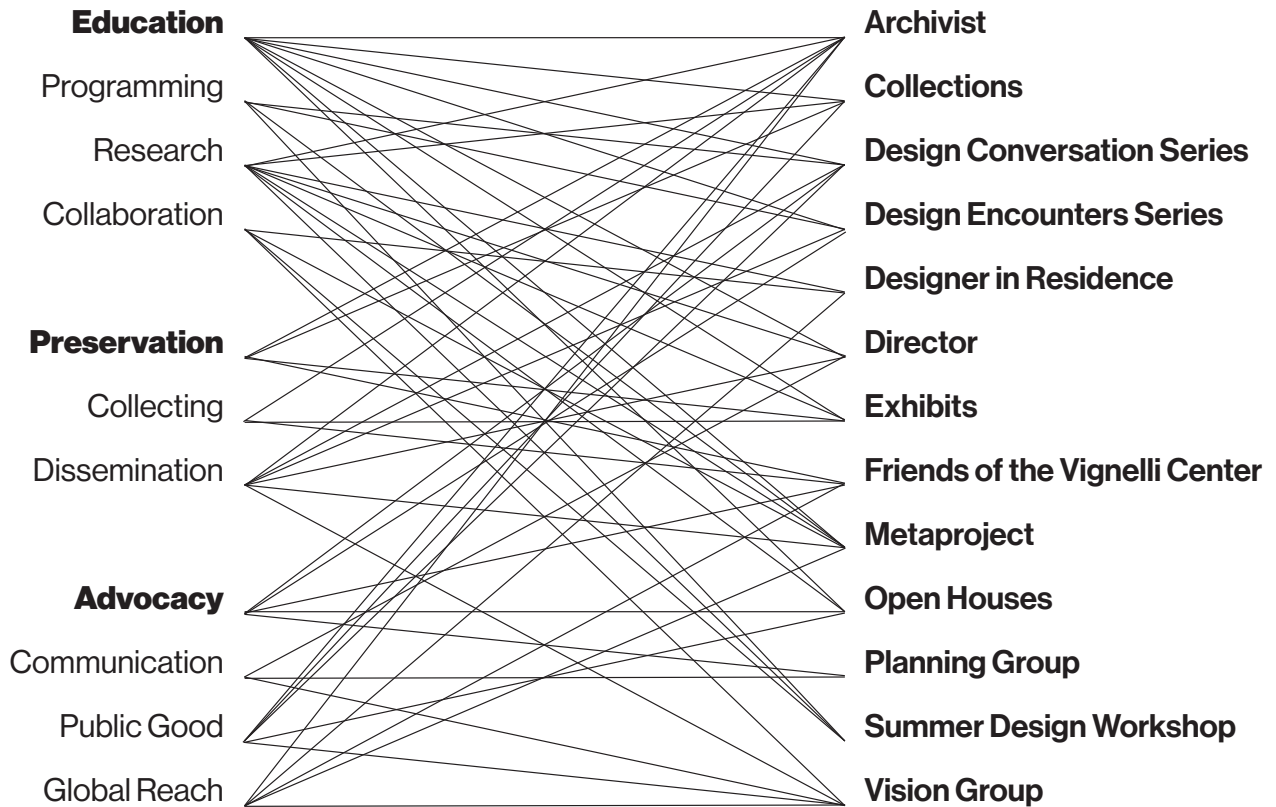

Goals

Education

Programming

Research

Collaboration

Preservation

Collecting

Dissemination

Advocacy

Communication

Public Good

Global Reach

Education

Programming

To develop, implement and report programming that enhances design curricula at RIT and beyond.

Research

To document the above in a systematic case studies format both in print and online application.
To promote innovative programming and related research that uses Vignelli archival resource.

Collaboration

To establish relationships with individuals and organizations that will extend goals of Vignelli Center.

Preservation

Collecting

To maintain, catalog, and use the Vignelli Archive.
To add Vignelli artifacts to the collection as opportunities arise.
To inform public of contents and breadth of Vignelli design accomplishments.
To expand modernist archive holdings providing breadth to the archive
To acquire select special collections that will complement Vignelli Archive
To acquire select design archive collections that will complement Vignelli Collection.
To extend archive collections toward balance of graphic and product design.

Dissemination

To use artifacts from Vignelli Archive as extension of Vignelli Legacy.
To share Vignelli Archive with world.
To apply social media platforms.

Advocacy

Communication

To implement the **Design is One** logo in Center promotions to create brand identity extending the Vignelli legacy.

To create mechanisms which will disseminate information about the Vignelli Center and its activities
To disseminate information about the Center and its activities.
To systematically document Vignelli Center activities.

Public Good

To demonstrate programming that will affect human need.
To demonstrate through programming the power of design.

Global Reach

To design and facilitate outreach mechanisms that will deliver messaging about design to international audiences.
To engage in international relationships which will foster global programming opportunities.
To develop special collections representative of international design excellence.
To share online the Vignelli Archive and the Vignelli Special Collections.

Overview

About

In 2010, renowned designers Lella and Massimo donated their career archive to RIT, where the collection is the major resource at the Vignelli Center for Design Studies. This world-class facility is a design museum accessible to all students, faculty, practitioners, and scholars. The Center, a prominent legacy to the Vignelli's and influential modernists, sustains the Vignelli goal of "better design for a better world." It is an international hub for education, preservation, and advocacy whose distinctive archival resources work in tandem with relevant programming to provide a dynamic learning environment on the RIT campus.

Mission

The Vignelli Center for Design Studies educates, preserves, and advocates for design to improve the world.

Vision

The archive collections housed in the Vignelli Center for Design Studies demonstrate and inspire solutions to key and ubiquitous societal needs. By providing opportunities for varied programming for diverse audiences, the Center extends the value of design for positive impact on the future.

Vignelli Ethos

Design is one.

Goals

Education
Preservation
Advocacy

Framework

At the heart of the Vignelli Center lies a dynamic and purposeful collaborative framework, orchestrated by a diverse ensemble of key contributors. The Center is comprised of the director, archivist, archives, galleries, designer in residence, friends, planning group, and vision group. Collaboratively, their efforts focus on projects that shape the center's future trajectory, amplify outreach, and ensure inclusive access for students and researchers to the invaluable archives, fostering a vibrant ecosystem of design exploration and knowledge exchange.



See the Vignelli Center in Action

www.rit.edu/vignellcenter/

Director

Role of Director

The director of the center plays a pivotal role in shaping the future of the center. Serving as the visionary anchor, the director curates a dynamic lineup of guest speakers, fostering a platform for diverse perspectives and insights to enrich the center's discourse. Beyond this, the director actively cultivates relationships, orchestrating donations and partnerships that propel the center's growth and sustainability. The Director also coordinate workshops that facilitate hands-on learning and creative exploration, driving the center's goal of education. The director embodies hospitality, extending a warm welcome to guests, researchers, and collaborators, creating an inviting atmosphere that encourages meaningful interactions and knowledge exchange. In essence, the director's multifaceted role harmonizes strategic vision, community engagement, and educational empowerment within the Vignelli Center.

Josh Owen

Josh Owen is the Vignelli Distinguished Professor of Design and the Director of the Vignelli Center for Design Studies at RIT. Prior to his current role, Owen was Director of the Industrial Design Department in which he continues to teach his popular course known as the Metaproject. Owen is also the president of his eponymous design studio, Josh Owen LLC. His professional projects are produced by major manufacturers and have won many awards. Owen's work is included in the permanent design collections of the Centre Georges Pompidou (FR), the Chicago Athenaeum (USA), The Corning Museum of Glass (USA), the Denver Art Museum (USA), the Design Museum Brussels (BE), the Museum of American Jewish History (USA), the Musee de beaux-arts de Montreal (CA), the Philadelphia Museum of Art (USA), and the Taiwan Design Museum (TP). Owen's professional work has been featured in major exhibitions, numerous books on design and is regularly included in critical design discourse. He is the author of the book, Lenses for Design and the forthcoming book, Design for Study.

Director 2023



Josh Owen, Vignelli Center Director

Photo by Alley Babcock

Archivist

Role of Archivist

The Archivist of the Center plays an essential role in the preservation of the artifacts and providing access to the collections. The Archivist is the primary contact for visitors who want to conduct research or find inspiration in the design archives. The Archivist is an ambassador to all who visit the archives, both virtually and onsite, ensuring that all inquiries are answered with equity and careful consideration. The Archivist manages virtual access to the archives by digitizing artifacts with careful consideration to their preservation and creates metadata to make the digital archives searchable. The Archivist is committed to making sharing the contents of the collections by highlighting artifacts through various social media channels. The Archivist is responsible for the management, organization, and cataloging of the over 750,000 artifacts, applying professional archives and museum standards to ensure the preservation and authenticity of the collections. The Archivist assists museums, curators and commercial industry partners with details about the Vignellis' designs, as well as advising on best practices in design archives.

Jennifer Whitlock

Since 2013, Jennifer Whitlock has been the first and only archivist for the Vignelli Center for Design Studies at Rochester Institute of Technology (RIT). Before arriving at RIT, Jennifer initiated an archives program for the Indianapolis Museum of Art, served as a project archivist and interim acting curator at the Architecture & Design Collection at University of California Santa Barbara, and also worked as an Assistant Librarian at the Portland Art Museum. She holds a Master of Library Science with an Archive Certificate from Emporia State University and a BA in Photography from Webster University. She is also a certified Archivist through the Academy of Certified Archivists and (formerly) a Digital Archives Specialist through the Society of American Archivists.

Archivist 2023



Jennifer Whitlock, Vignelli Center Archivist

Designer in Residence

Role of Designer in Residence

The role of the Designer in Residence is to further the educational mission by engaging with stakeholders and departments of students. The Designer in residence brings valuable knowledge from beyond the archive's confines, infusing fresh and innovative ideas into its practices. The Designer in Residence engages with various departments and stakeholders, fostering a dynamic exchange of insights and expertise. This collaborative approach enables the Designer in Residence to contribute diverse viewpoints and creative solutions that enhance the overall function and impact of the archives.

Reza Aliabadi

RZLBD (Reza Aliabadi) is a Canadian architect of Persian origin. He is the founder of Atelier RZLBD, an art and architecture practice based in Toronto, whose work extends to making arts, crafting objects, designing buildings, curating installations, and publishing a zine called rzlbdPOST. From a 17 mm wedding ring to a 56 km long housing proposal, his portfolio has been distinguished with numerous accolades including the International Architecture Master Prize (2018, 2019, 2020, 2021, 2023) American Architecture Prize (2017) and Ontario Association of Architects Awards (2009, 2011); exhibited in many venues including the Sir John Soane's Museum (London 2018) the World Architecture Festival (Berlin 2017, Amsterdam 2018) the School of Architecture at McGill University (Montreal 2009, 2017) and Toronto Harbourfront Centre (2012); and celebrated in more than one hundred print publications. In 2017 RZLBD has been selected among the top emerging design talents in Canada. In the same year the UK publisher Artifice released a monograph, RZLBD HOPSCOTCH, which recognizes Aliabadi's selected built projects by collecting essays, project profiles, and annotated drawings. RZLBD's new book, The Empty Room, was released by Actar Publishers in 2020.

Designer in Residence 2023



Reza Aliabadi, Vignelli Center Designer in Residence

Vision Group

Role of Vision Group

Seasoned designers, possessing both commercial and academic expertise, come together as visionary leaders shaping the future of the Vignelli Center. Their primary focus lies in steering significant, long-term projects, as well as addressing overarching goals and critical matters.

Group Members

Anne Ghory-Goodman
Gene DePrez
James Marotto
R. Roger Remington
Su Mathews Hale

Vision Group 2023



Anne Ghory-Goodman



Gene DePrez



James Marotto



R Roger Remington



Su Mathews Hale

Planning Group

Role of Planning Group

The Vignelli Planning Group comprises faculty, staff, and students from both undergraduate and graduate programs. The Group meets weekly throughout the academic year around the Hamlyn Trust Study Room Table. The Vignelli Planning Group discusses and plans short-term projects, ideates and enacts the activities of the Vignelli Center. The meetings cover many topics such as upcoming events and lectures, open houses, Metaproject, and student involvement.

Faculty & Staff

Anne Jordan
Annie Browar
Elizabeth Lamark
Enid Cardinal
James Hall
James Marotto
Jason Arena
Jennifer Whitlock
Josh Owen
Joyce Hertzson
Keli DiRisio
Juliee Decker
Julius Chiavaroli
Maddy Schoenfeld
Marissa Tirone
Mark Kingsley
Mary Golden
Melissa Dawson
R. Roger Remington
Samantha Haedrich
Shani Avni
Terri Lee
Wendy Marks

Department

Visual Communication Design
Marketing + Communications
Photography
Sustainability
School of Individualized Study
Advancement
New Media Design
Vignelli Archivist
Vignelli Director
Graduate Studies
Graphic Design
Museum Studies
Architecture
Business
Foundations
Cary Professor
Interior Design
Industrial Design
Graphic Design
Graphic Design
Cary Graphic Archives
Interior Design
Shop One

Students

Ana Videto
Annelize Wall
Gates Andrews
Ipek Koprululu
Isabelle Qiu
John Bechtold
Laura Woodrow
Liza Lennarz
Shreya Talegaonkar
Tayo Oke
Zoë Murray

Major

Graphic Design
New Media Design
Industrial Design
Visual Communication Design
Visual Communication Design
Visual Communication Design
Visual Communication Design
Graphic Design
Visual Communication Design
Industrial Design
Graphic Design

Planning Group 2023



Friends of the Vignelli Center

Role of Friends

As part of our tenth anniversary and in honor of R. Roger Remington, the Massimo and Lella Vignelli Distinguished Professor of Design Emeritus and the founding Director of the Vignelli Center for Design Studies, a generous donor has established the R. Roger Remington Fund for the Vignelli Center for Design Studies. Gifts will be matched up to \$100,000. Help us meet this challenge by joining as a friend of the center with a contribution to the R. Roger Remington Fund for the Vignelli Center for Design Studies.

Impact

- Diversify, expand and maintain the archives through new acquisitions and preservation
- Host thought leaders, visiting professors, and scholars.
- Promote design education
- Share ideas through conferences, publications, social media, and collaborations
- Support research and scholarship.
- Increase virtual access to the collection
- Celebrate the history and promote the future of design

Design is One Believer**\$15,000+**

All of the preceding benefits plus:
An invitation to Design Week in Milan for a walking tour and conversation led by Josh Owen including an exclusive private tour of the Studio Achille Castiglioni, Massimo Vignelli's first place of employment as a young designer with Josh and Giovanna Castiglioni. Acknowledgment in our publications, social media, and marketing.

Anonymous
Mr. Bailey
Ms. Vignelli

Design Aficionado**\$5000–\$14,999**

All of the preceding benefits plus:
An event Invitation for Design Advocates during Design Week in New York.
An Invitation to private events with our guest speakers after their lectures.
A set of Vignelli dinnerware.

Ms. Napier

Design Devotee**\$1000–\$4999**

All of the preceding benefits, plus:
A personalized tour of the archive.
A design book written by Josh Owen or R. Roger Remington.
An exclusive conversation with R. Roger Remington and Josh Owen.

Mr. Blacksberg
Mr. & Mrs. Feingold
Mrs. Hale
Mr. & Mrs. Kababulut
Mr. Paulius
Mr. & Mrs. Resnick
Mr. Teper

Design Champion**\$250–\$999**

All of the preceding benefits, plus:
An exclusive Vignelli designed item.

Mr. Adams
Mr. Aliabadi
Mr. Boches
Mr. & Mrs. Corea
Dr. Cummings
Mr. Daniels
Mr. & Mrs. Deprez
Ms. Fitzgerald
Mr. Skrok
Mr. & Mrs. Wadden

Design Enthusiast**\$50–\$249**

Special invitations to Design Conversations and Design Encounters lectures series.
A Quarterly Vignelli Center for Design Studies Newsletter.
Donor recognition on the Vignelli Center website.
Design is One pin.

Mr. Appleton & Ms. Ishino
Mrs. Dragon
Ms. Frear
Dr. Galbraith

Student of Design**\$10–\$49**

Special invitations to Design Conversations and select Design Encounters lectures.
A Quarterly Vignelli Center Newsletter.



Armani
nova



Armani Fine
Jewelry

12002/1000





Archives 2023

About the Archives

The Vignelli Center for Design Studies is committed to preserving the history of design through collecting the archives of designers, historians, educators, collectors, filmmakers, and others who document design's past. Our collections are open to everyone for research, education, and creative inspiration.

With a collection of over 750,000 artifacts, the Vignelli Center is home to the entire professional

archives of the renown designers Massimo and Lella Vignelli, including two floors of galleries highlighting the Vignelli work which is open to the public. Massimo and Lella Vignelli worked across all fields of design and their archives include examples of industrial and product design, graphics and publication design, corporate identity programs, architectural graphics, exhibitions, interiors, and furniture design. The collection also features unique

materials related to the Vignellis' design process, such as sketches, prototypes, models, technical plans, correspondence, contracts, mechanicals, photographs, material samples, videos, and digital files.

In addition to the Vignelli archives, the Vignelli Center has 1000s of artifacts by numerous additional designers in our Special Collections.

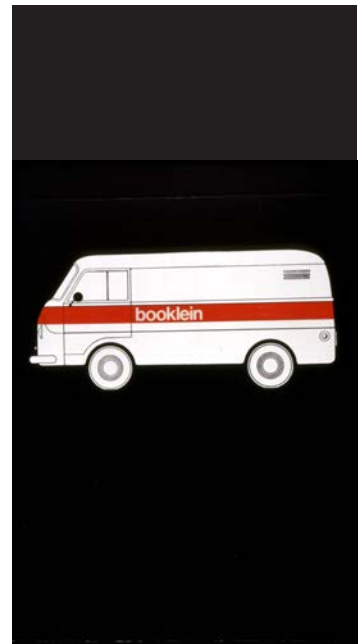

Found in the Vignelli Archives

Unknown Vignelli-designed graphic identity project for Booklein retail stores which sold paperbacks, magazines, and newspapers.

Archives Snapshot

328 inquiries from 12 different countries answered

Research inquiries
+58% since 2022
+1071% since 2013

4,500 digital images of artifacts shared with researchers

2,484 digital archives visitors per month from 69 countries

1025 visitors for research visits, class sessions, open houses and tours.

The Institute for Architecture and Urban Studies

Eight West Fortieth Street, New York, N.Y. 10018
Telephone: 212 398 9474

KAZUO SHINOHARA

11 Houses (1971-1976)

This exhibition was made possible with funds from
the New York State Council on the Arts.

December 8, 1981-January 8, 1982
Monday through Friday, 9-5

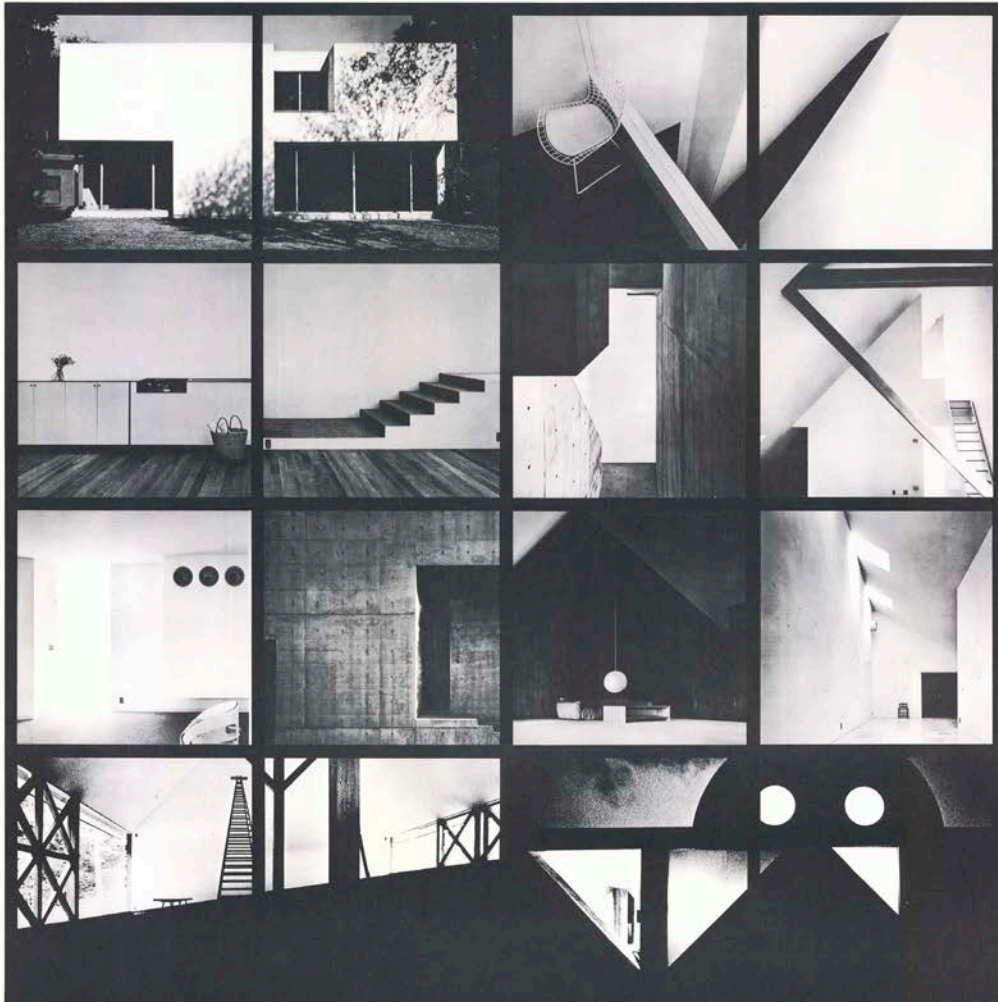

Poster for Kazuo Shinohara Exhibition

Exhibits

Benetton Gallery Second Floor

Located on the ground level and accessed through the University Gallery, this selection of Vignelli-designed products, graphics and packaging was curated by the Vignelli's themselves. This grouping shows the substantial range and impact of their work.

Benetton Gallery Third Floor

As with the second floor gallery, this selection of furniture designed by the Vignelli's was also curated by the Vignelli's. Represented here, one can find a variety of pieces ranging from mass-reproduced items to items produced in extremely limited quantities which incorporate materials including plastics, metals and wood as well as glass and stone.

Helen Hamlyn Trust Study Room

Located on the fourth floor of the Vignelli Center. The room hosts meetings and discussions and showcases changing displays of work produced by participants and friends of the Vignelli Center.

Special Exhibits in the Archives

Additional curated selections from the archives collections can be found on limited view by appointment or invitation on the fourth floor within the archives. The nature of these exhibits is determined by the Archivist or the Director.



Design:Vignelli

In 1971, Vignelli Associates was founded in New York by Lella and Massimo Vignelli to work in the whole field of design: from graphic programs to books, magazines and newspapers, from transportation design to packaging and product design, and from furniture design to interiors and exhibition design.

Vignelli Associates' basic design belief is that "Design is One." We believe in discipline as the pursuit of structural integrity, appropriateness as the search for the specific, and ambiguity as a plurality of meanings. We believe that a designer should be able to design anything--"from the spoon to the city"--because the basic discipline of design is one; the only things that change are the specifics. We believe that the interaction between different experiences enriches the mind and that specialization creates entropy. We strongly believe in the social responsibility of the designer, and that design is an integral part of the production process, not an embellishment.

Benetton Gallery, Second Floor

Entering from University Gallery



Benetton Gallery, Second Floor

Vignelli exhibition curated and designed by Lella and Massimo Vignelli



New Acquisitions 2023

Each year our collections continue to grow with select additions which help to make the archives the most complete record possible.

Acquired in 2023

- Frederick Burbach Swiss Posters collection
- Design: Vignelli traveling exhibition 1989-1992
brochures, catalogs, and documents
- Simon Jennings (Unimark) addition [35mm slides]



Material Archiv Gewerbemuseum Winterthur (2016)

Poster by Alexandra Noth from Frederick Burbach Swiss Posters collection

Research 2023

Scholars, historians, curators, designers, journalists, publishers, manufacturers, former Vignelli clients, social media influencers, and many others access the archives for a variety of research, publications, exhibitions, and inspiration.

Inquiries are up 58% from 2022 with 328 inquiries from 12 different countries. The Archivist shared over 4500 digital images with researchers.

Highlights 2023

- French student thesis on the NYC Subway map
- RIT Museum Studies and Imaging Science exhibit on multispectral imaging
- Knoll Dubai showroom poster reproductions
- Google Arts & Culture Italy virtual exhibition on Italian design (upcoming)
- Publication research, image support, and permission requests for numerous publishers
- Supporting industry and Vignelli clients for research, manufacture, and promotion of Vignelli designs

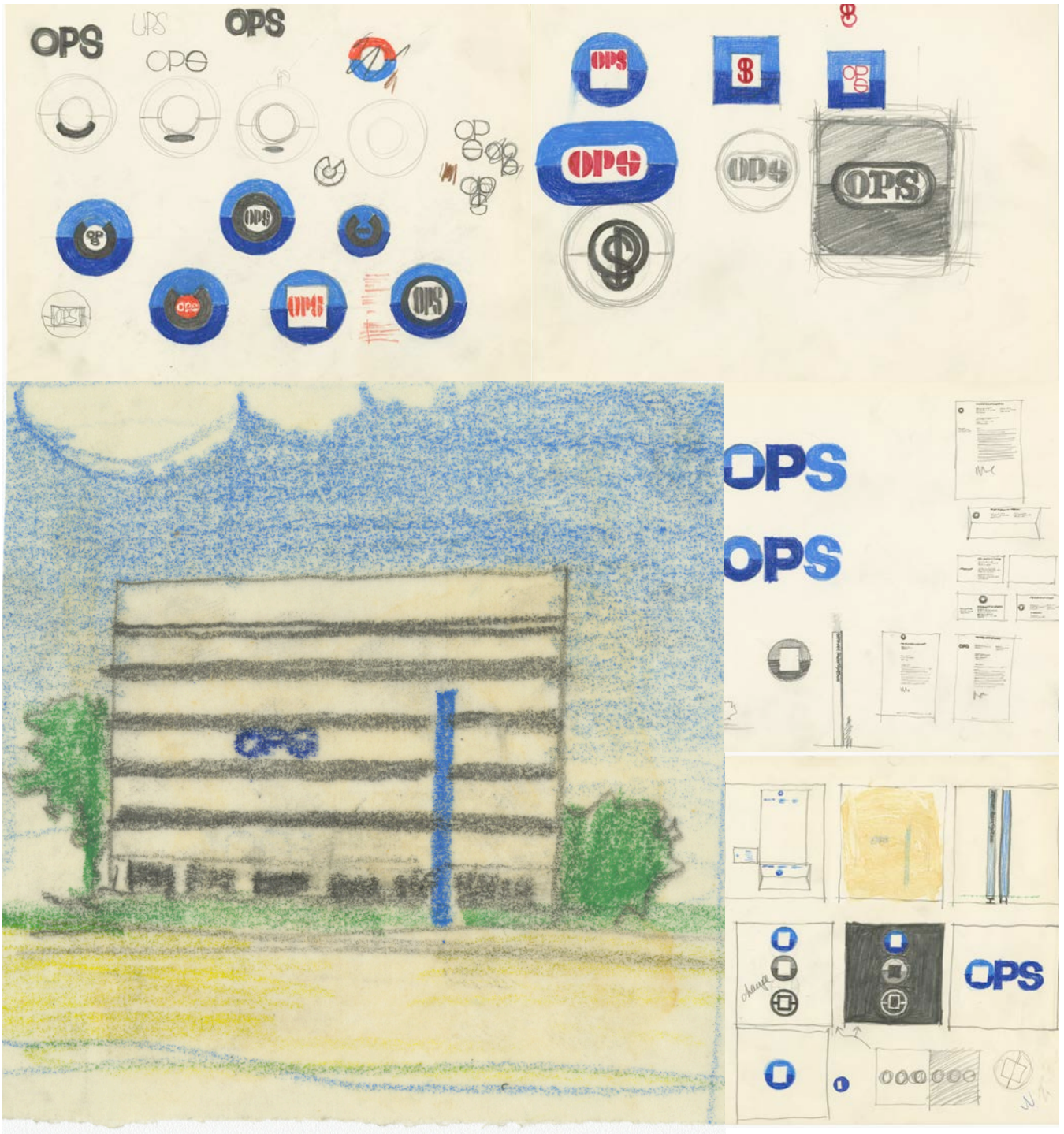

Graphic Identity System for Offshore Power Systems

Various artifacts for the OPS graphics including sketches by Massimo Vignelli



Vignelli Associates
Designers

475 Tenth Avenue
New York, New York 10018
Phone 212/244 1919
Fax 212/967 4961

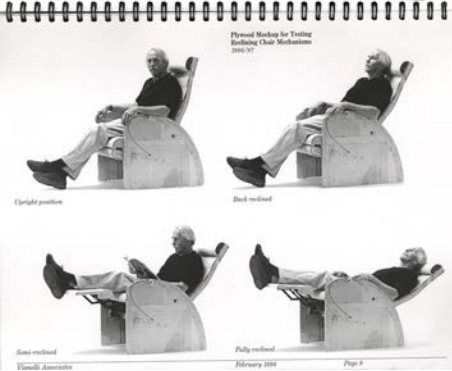
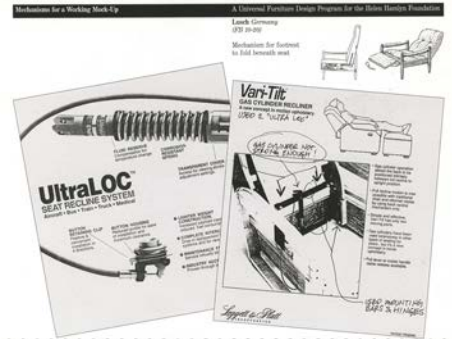

A Universal Furniture Design Program for the Helen Hamlyn Foundation



A Universal Furniture Design Program for the Helen Hamlyn Foundation

Designed by Vignelli Associates

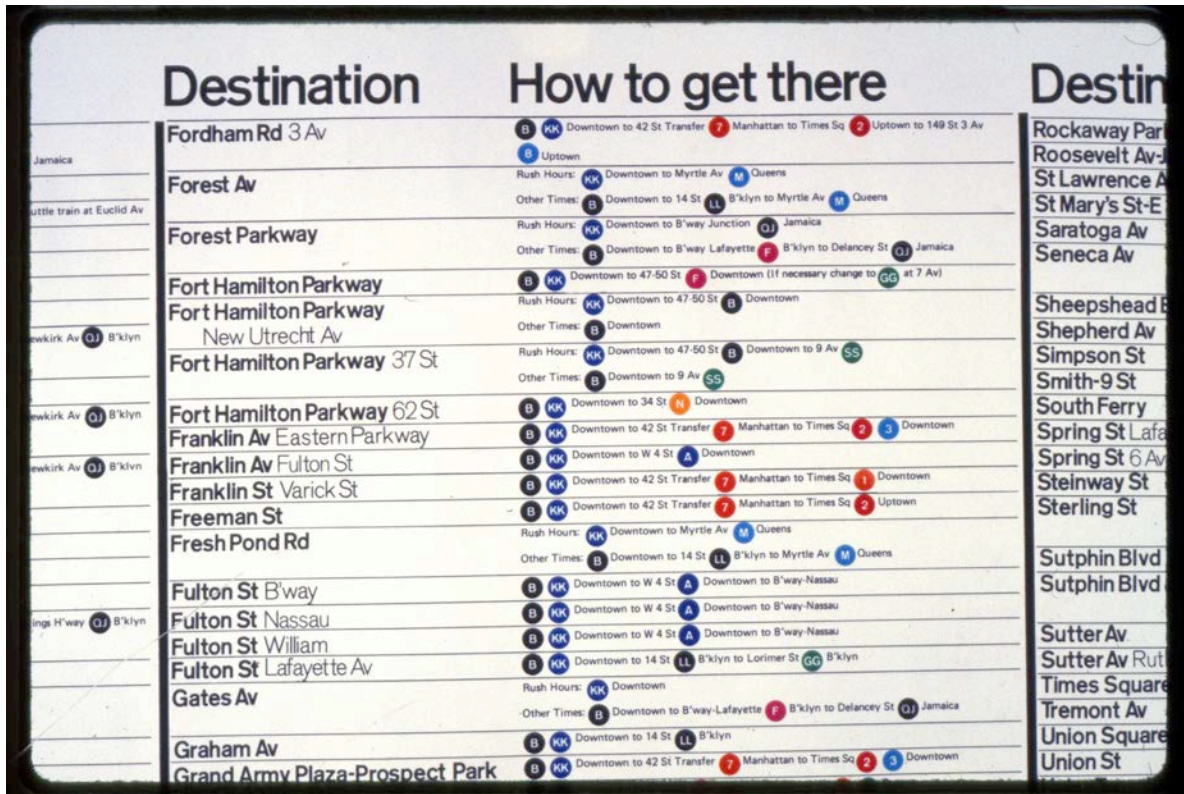
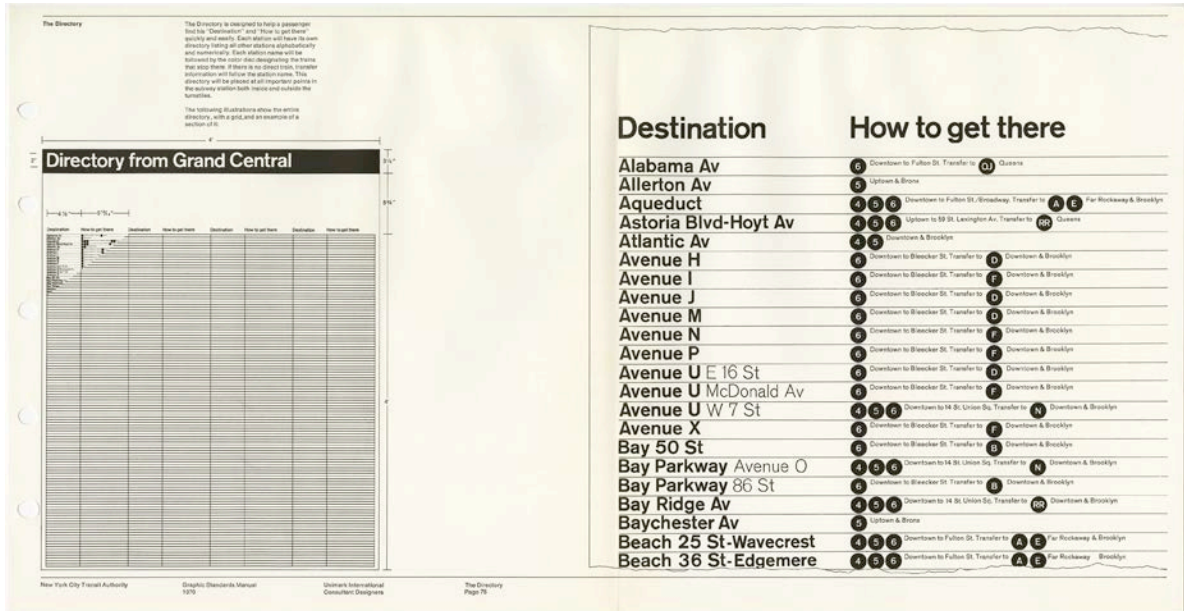

NYC Subway Verbal Map

Vignelli designed 4 maps to convey different information.

The Verbal map described how to reach a destination, which train to get, where to change and when to get out

Education 2023

The Archivist partners with faculty and students to integrate collections into the curriculum and teaching course sessions with artifacts across a variety of disciplines. Faculty around the world use digital images in their courses and students around the world find inspiration for their projects and incorporate the archives into their dissertations, theses, and projects.

Highlights 2023

- Taught 10 class sessions [1 virtual on Zoom] in addition to dozens of courses who attended Open Houses: RIT's Photo, 2D/3D Foundations, Industrial Design, New Media, Art, Graphic Design/VCD and Museum Studies
- Providing artifacts for multi-spectral imaging research with faculty and students in Museum Studies and Imaging Science
- RIT Photo Content Management course used Vignelli archives artifacts to learn about digital asset management and metadata (5th year)
- 3 days of archives displays for summer workshop hosted by Vignelli Center for professional designers



Sketches from the Vignelli Archives

Design process artifacts like sketches are an invaluable resource for students of design. Photo: Traci Westcott/RIT



2023 Summer Design Workshop

Participants of the 2023 Summer Design Workshop engaged with the Archives and Archivist Jennifer Whitlock in order to come up with their final lamps



Metaproject 14

Students in the Metaproject course frequently utilize the Archives as an educational tool and as hands-on guidance in solving their design problems

Collections



Saint Peter's Church, New York City, NY

Lella and Massimo designed everything in the space, from the pews to the organ to the ritual objects used during services



Vignellis with Heller products

Lella and Massimo Vignelli photographed with the colorful plastic dishware and glass bakeware they designed for Heller

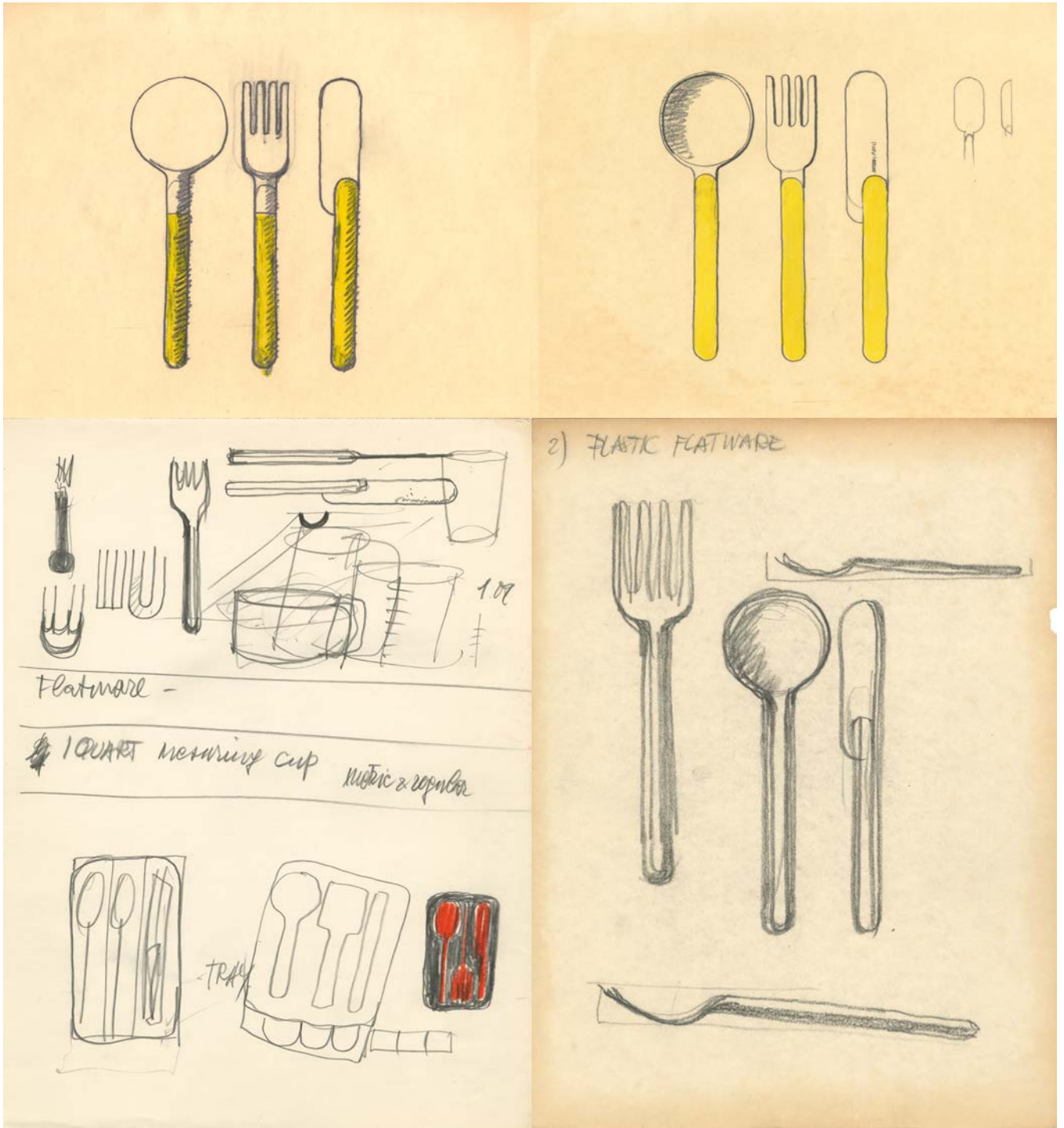

Heller Plastic Flatware

Sketches of plastic flatware, designed for Heller, which was never produced.



Identity for the Brooklyn Museum of Art

Vignelli Associates updated the graphic identity system for BMA in 1998



Photo by Georgia Pressley



Programming 2023

Open Houses

About Open Houses

RIT's Vignelli Center for Design Studies Open House series welcomes the RIT and Rochester communities to the center and its archives for dedicated multi-day events over the course of the academic year. Under the expert curation of Jennifer Whitlock, each open house is thoughtfully curated around a meticulously chosen theme, providing a unique and captivating display at every event. The primary objective of these open houses is to showcase the iconic works of the Vignelli's. These events offer a chance for visitors to engage with precious archive material, honoring the Vignelli's wish for scholarly study and deepening our understanding and appreciation of design history.



Artifacts from the Vignelli Archive

History

Origins and Inspirations

Archives can seem like mysterious places hidden behind locked doors and can be intimidating to nonscholars to navigate. Still, students, faculty, designers, and other art history enthusiasts are interested in what lies behind closed doors. Open Houses provide visitors with a chance to interact with artifacts pulled from the vault without an appointment. Informal pop-up style displays of hundreds of artifacts provide visitors a chance to see and interact with design history both the iconic and the unexpected. Open Houses primarily showcase the iconic works of the Vignellis, but often highlight artifacts from our Special Collections too.

Organizers



Jennifer Whitlock

Open house curator and host



Josh Owen

Open house host

2023 Open Houses

Date	Information	Impact
January 25–26	Theme: Architecture	• Attendance: 75
February 22–23	Theme: Typography	• Attendance: 83
March 22–23	Theme: Photography	• Attendance: 113
September 20–21	Theme: Design is One	• Attendance: 165

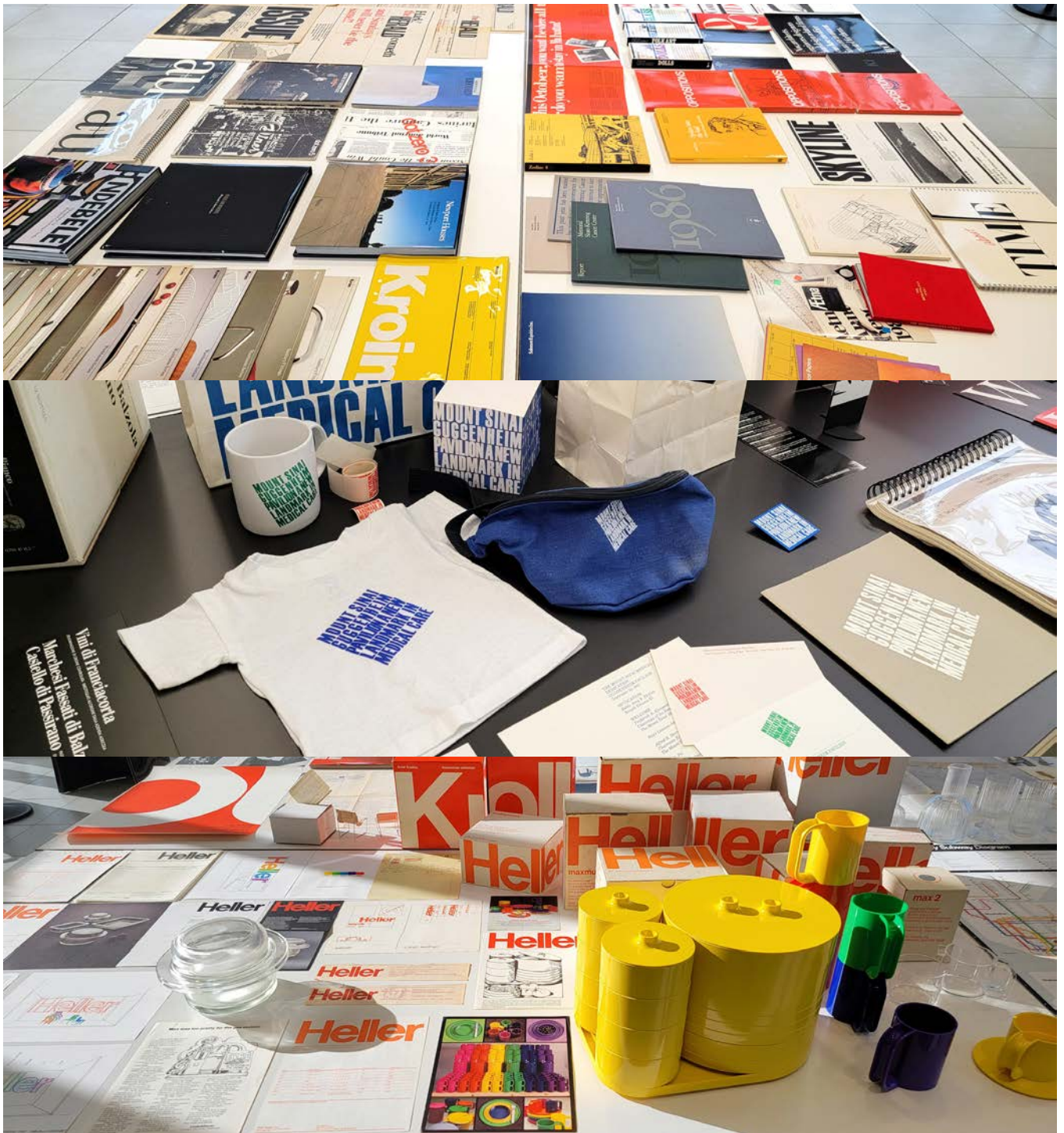

Open Houses from 2023

Snapshots from different Open Houses throughout the year

Design Conversation Lecture Series

About the Series

Central to the Vignelli Center's role in promoting vital design discourse is the Design Conversations lecture series which brings important design-minds to RIT, exposing our community to a lineup of diverse and creative visionaries throughout the academic year. In a first-of-its-kind partnership with the popular online design destination Design Milk, the Center has dramatically expanded its reach for this annual lecture series by rebroadcasting the Design Conversations talks through their channels.



Design Conversation Lecture Series

Presented by Design Milk

History

Origins and Inspirations

The Design Conversation Lecture Series aligns with the educational mission of the Vignelli Center. This series facilitates valuable learning opportunities for both students and community through inspiring lectures by renowned professionals and Vignelli Center contacts.

Organizers



Josh Owen

Director



Jennifer Whitlock

Archivist

Design Conversation Lecture Series 2023

2023 Lecturers

- Debbie Millman
- John Edelman
- Patricia Moore
- Richard Poulin

2023 Topics

- Why Design Matters: the importance of personal projects
- Career trajectory of John Edelman
- Universal design
- The life and work of Rudolph de Harak

Design Conversation Lecture Series 2023



Debbie Milman



John Edelman



Patricia Moore



Richard Poulin

Design Encounters Lecture Series

About the Series

Design Encounters is an informal series for the RIT community to share and explore flexible, open-ended discussions that cover a wide range of topics and perspectives related to all design professions. The series is hosted as a searchable digital collection on the VCDS YouTube and website. It provides students and community members with helpful insights and enriching learning experiences.

History

Origins and Inspirations

The Design Encounter Lecture Series was begun to enable students and the design community to continue learning during the COVID-19 Global Pandemic.

Organizers



Josh Owen

Director



Jennifer Whitlock

Archivist

Design Encounters Lecture Series 2023

2023 Lecturers

- Mitch Goldstein

2023 Topics

- How to Be a Design Student
(and How to Teach Them)

Design Encounters Lecture Series 2023



Mitch Goldstein

Beyond Fashion Show

About the Show

The Beyond Fashion show is an annual event showcasing student talent at RIT, underscoring a partnership between designers artists and students of the craft areas in RIT's College of Art and Design and the Rochester community. It is a showcase of a diverse collection of garments and wearables inspired by the Vignelli Archives. The pieces represent each designer's interpretation of Lella and Massimo Vignelli's iconic design theory, informed by a browse of the tangible Vignelli Archives and the center's Google Arts & Culture digital collection.



Beyond Fashion Show 2023

History

Origins and Inspirations

The Beyond Fashion show is an annual event that was started by RIT students Maddy Schoenfeld and Julia Abbonizio. They partnered to plan the even as an independent study.

Founders



Maddy Schoenfeld

“Community is the most important thing that I gained from RIT.”



Julia Abbonizio

“This project has been one of the most enriching experiences I’ve had during college.”



Josh Owen

“Besides having a global impact, making a local impact is also very important for us.”

Beyond Fashion Show 2023

2023 Theme

The Grid is Everything

2023 Organizers

- Maddy Schoenfeld
- Etta Arnold
- Emma Williamson
- Alley Babcock
- Josh Owen

2023 Community Designers

- Wendy Marks
- Pat Pauly
- Andrew Scott
- Margaret Manders
- Rita DeNicuolo
- Kelly Gampietro

2023 Student Contributors

- RIT New Media Design
- RIT Fabrick
- RIT Metals
- RIT Industrial Design

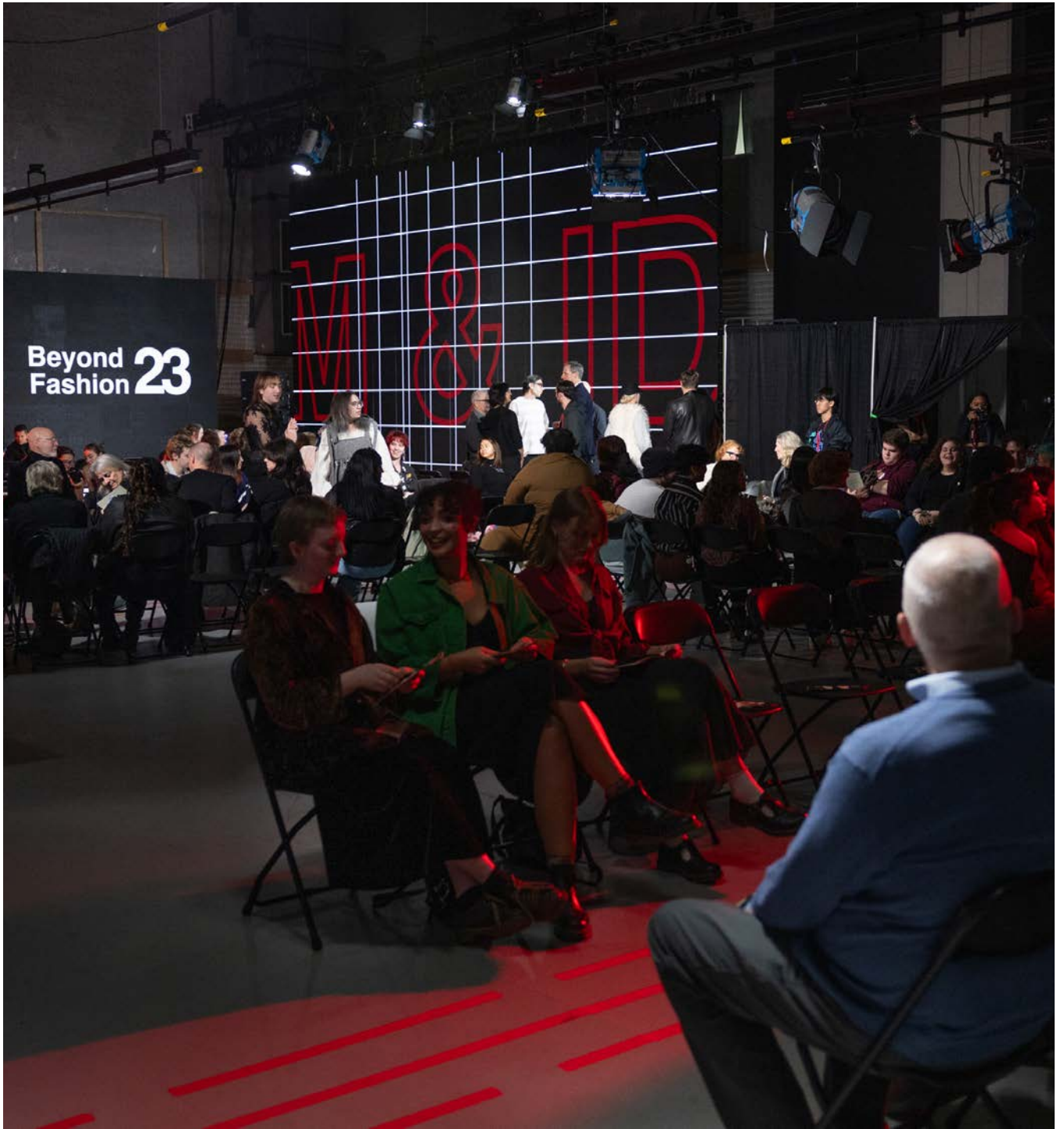

Beyond Fashion Show

Photo by Quinn Freidenburg



Designer Pat Pauly walking the runway

Photo by Tara Bryan





Beyond Fashion Show

Model in work by Fishy Patchwork

Photo by Jack Conolly





Beyond Fashion Show

Audience watches sold out fashion show

Photo by Jack Conolly



Summer Design Workshop

VCDS + CMOG

About the Workshop

An invitation for up to 10 students and designers from the global art community to participate in a week-long workshop that is divided between the Vignelli Center for Design Studies at RIT in Rochester, New York and The Corning Museum of Glass in Corning, New York. Inspired by the Vignelli Archives, participants will develop a project of their own design that they will explore under the supervision of Vignelli Center staff and through the facilitation of master craft glass blowers from The Corning Museum of Glass. Participants will enjoy a week experiencing the food and culture of the Finger Lakes Region in late spring while connecting with unique design resources found in Upstate New York. Each participant will leave with a 3D printed prototype from the RIT Fab Lab and their final glass project fabricated at The Corning Museum of Glass. Over the course of the workshop, designers will be introduced to the extensive archives of the Vignelli Center that catalogs decades of process and innovation while finding their own voice in the iconic and challenging art form that is glasswork.



Inside the Corning Museum of Glass

Summer Design Workshop participants visit the museum for tours before heading to production meetings with master glass blowers to create their designs

History

Origins and Inspirations

The Summer Design Workshop is inspired by the Vignelli archives. The course aims to provide participants with a deep understanding of the relationship between 20th-century Modernism, current/future design challenges, and the Vignelli Ethos. Participants are encouraged to incorporate these insights into their own design goals and create innovative products or services that address the demands of the 21st century.

Key Stakeholders



Josh Owen, RIT

Vignelli Center Director



Erik Meek, CMoG

Manager of CMoG Hot Glass Team



Kitren VanStrander

Business Manager

2023 Summer Design Workshop

VCDS + CMOG

2023 Project

The typology of the CURRENT PROJECT was selected for participants of this workshop to consider because of its universal employment as a designed object. Nearly all cultures have created and utilized vessels to contain flowers or other objects of beauty. Must a vase be for use with flowers? At times a vase is an art object. Sometimes a vase is a story-teller. Could a vase have an alternative function? The focus of each individual's vase is their choice.

After studying the Vignelli's works and processes, participants will design and produce high-quality, full-scale functional prototypes. Later, workshop facilitators will help each participant create a digital 3D model which will be printed for them in translucent material which simulates glass. These models will serve as the reference material for the master glass blowers at Corning to work from to create the final products.

2023 Workshop Team

- Josh Owen, Project Leader
- Jennifer Whitlock, Project Partner
- Eric Meek, Workshop Partner

2023 Participants

- Reza Aliabadi
- Lori Resch
- Maria Canale
- Mark Havens
- Melissa Dawson
- Matt Silverman
- Paul McGroary
- Peter Rossetti
- John Bechtold



2023 Summer Design Workshop Participants

Left to Right: Paul McGroary, Mark Havens, John Bechtold, Peter Rossetti, Josh Owen, Maria Canale, Josh Owen, Maria Canale, Melissa Dawson, Matt Silverman, Reza Aliabadi, and Lori Resch



2023 Summer Design Workshop + CMoG

Workshop participant studying Vignelli archive material





2023 Summer Design Workshop + CMoG

Director, Josh Owen, facilitating workshop project development





2023 Summer Design Workshop + CMOG

Participants viewing inspirational artifacts



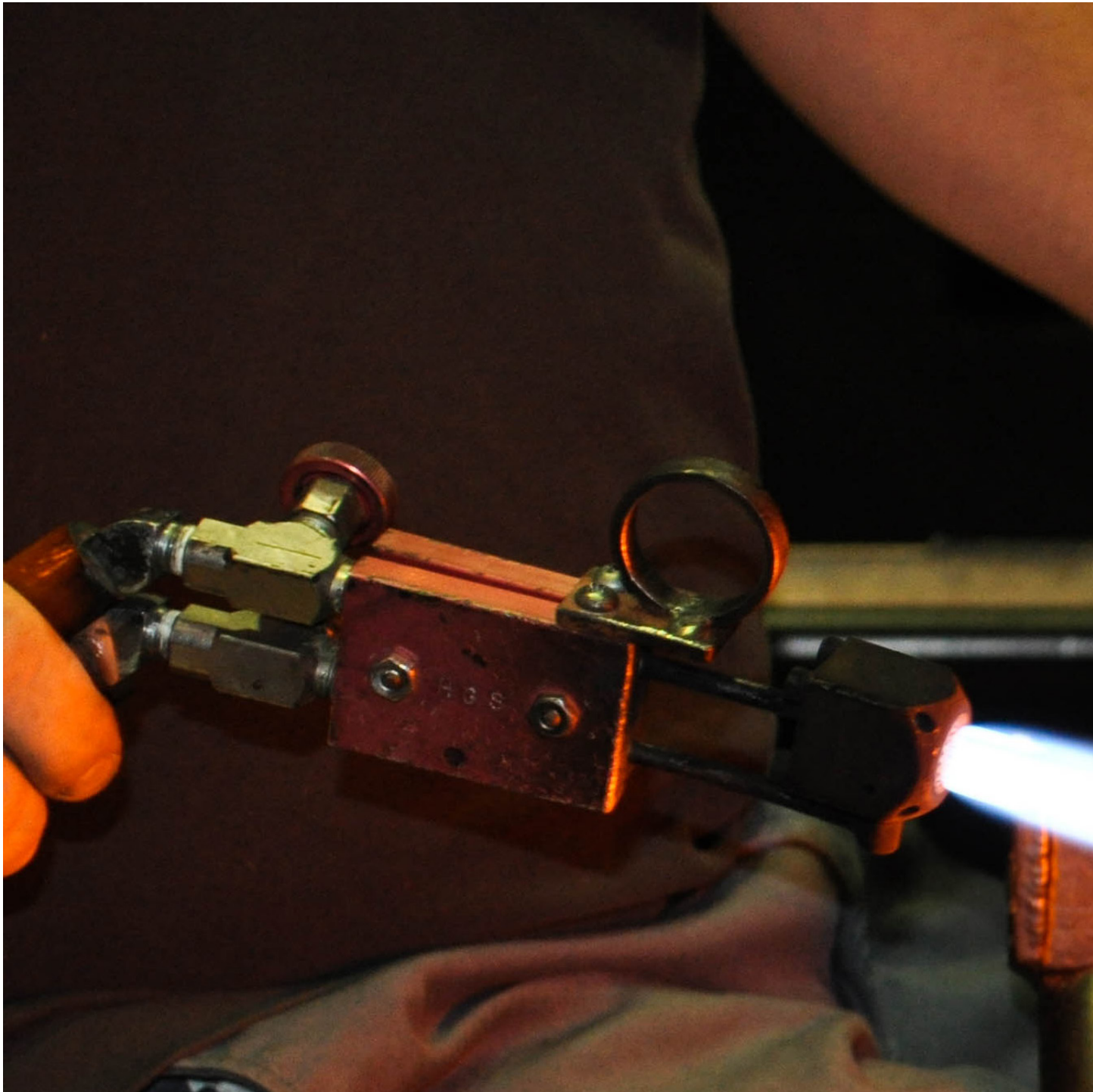

2023 Summer Design Workshop + CMOG

Production of final lamps in progress





2023 Summer Design Workshop + CMOG

Glass blowing at the Corning Museum of Glass





Summer Design Workshop 2023, Final Projects

Inspired by Vignelli archives, designed by workshop participants, and brought to life with CMOG's Master Glassblowers



Action shots of Summer Design Workshop 2023

Metaproject

About the Class

The term “Metaproject” is designed to be used as a thematic umbrella referring to an industry partnership which places the student output into a global venue thereby opening up a transformative platform for the industrial design program and by proxy, the School of Design and RIT. In keeping with the Design is One philosophy espoused by the RIT Vignelli Center for Design Studies, Metaproject aims to encourage students to produce design that is “semantically correct, syntactically correct, and pragmatically understandable, but also visually powerful, intellectually elegant and timeless”. Metaproject The course is taught by Josh Owen, Vignelli Distinguished Professor and Director of the Vignelli Center for Design Studies, and assisted by MFA candidate Paige Smith, Graduate Industrial Design Student.

The image shows the official logotype for 'metaproject'. The word 'metaproject' is written in a bold, lowercase, sans-serif typeface. The letters are white and stand out prominently against a solid black rectangular background. The 'm' and 'p' are particularly large and have a distinctive, slightly rounded, modern feel. The overall composition is centered and minimalist.

Official metaproject logotype

History

Origins and Inspirations

Professor Josh Owen, renowned in Industrial Design and serving as Director of the Vignelli Center, introduced Metaproject 01 in 2011. Since then, this course has remained a sought-after annual opportunity for senior undergraduates in RIT's industrial design program. Rooted in the teachings of design visionaries Lella and Massimo Vignelli, the class embraces their "Design is One" philosophy. This renowned class provides students with invaluable opportunities and connections, collaborating with esteemed industry partners including Herman Miller, Modkat, Lazzoni, and numerous others.

Notable Alumni

- Dylan Malone, Metaproject 13
- Richard Yu, Metaproject 12
- Hunter McCluer, Metaproject 11

Project Leaders



Josh Owen

Professor of Industrial Design and Director of the Vignelli Center



Reza Aliabadi

Vignelli Center Designer in Residence



Paige Smith

Graduate assistant

Metaproject 14

Industry Partner

- Rochester Institute of Technology

Students

- Elise Amorati
- Mingyu Han
- Emily Hogan
- Chase Kahn
- Daechan Kim
- Andrew Lin
- Margaret Manders
- Sydney Neff
- Peter Niebanck
- Jaimeson Pleasants
- Jules Reinhart
- Leah Rosen
- Mason Strange
- Alyssa Tenny

Metaproject 14 Winners

All students' projects are considered for construction.

Key Stakeholders



Josh Owen

Professor of Industrial Design
and Vignelli Center Director



David Munson

RIT President

Metaproject 14 Logo

The logo consists of the word "metaproject" in a white, lowercase, sans-serif font, followed by the number "14" in a bold, orange, sans-serif font. The entire logo is centered on a dark gray background.

metaproject 14

Logo featuring Metaproject 14's official color—orange



Metaproject 14 in Progress

Various snapshots as the Metaproject team comes to their final solutions



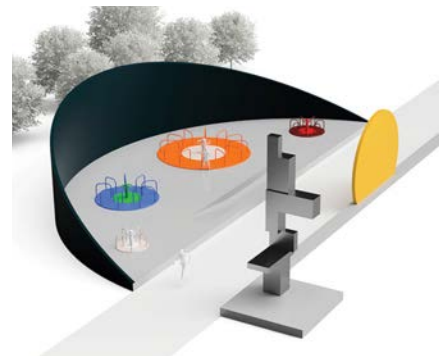
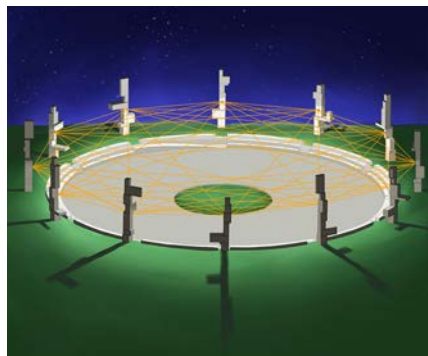
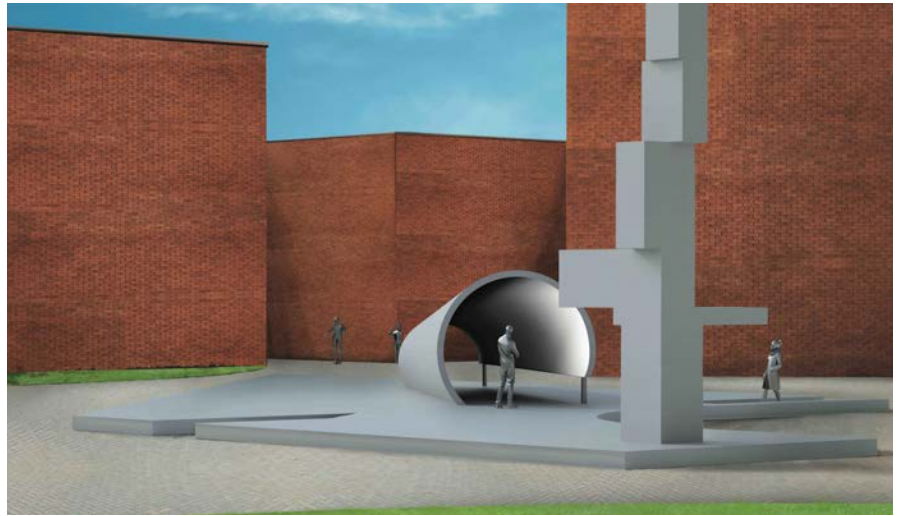

Metaproject 14 Projects

All students' projects are considered for construction

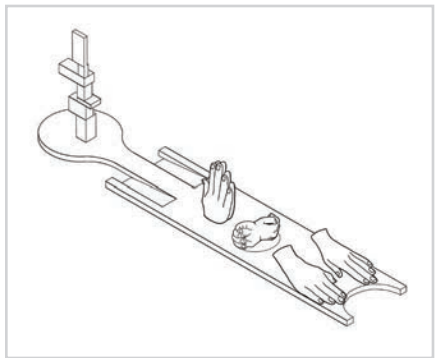
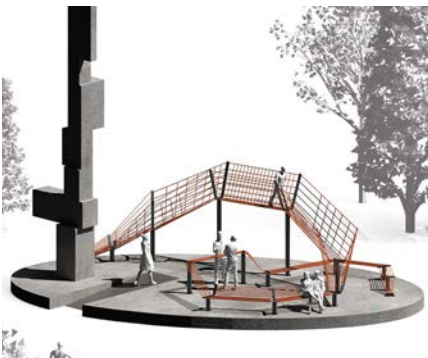
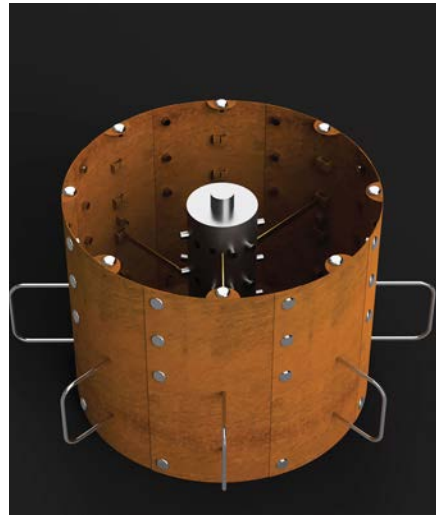
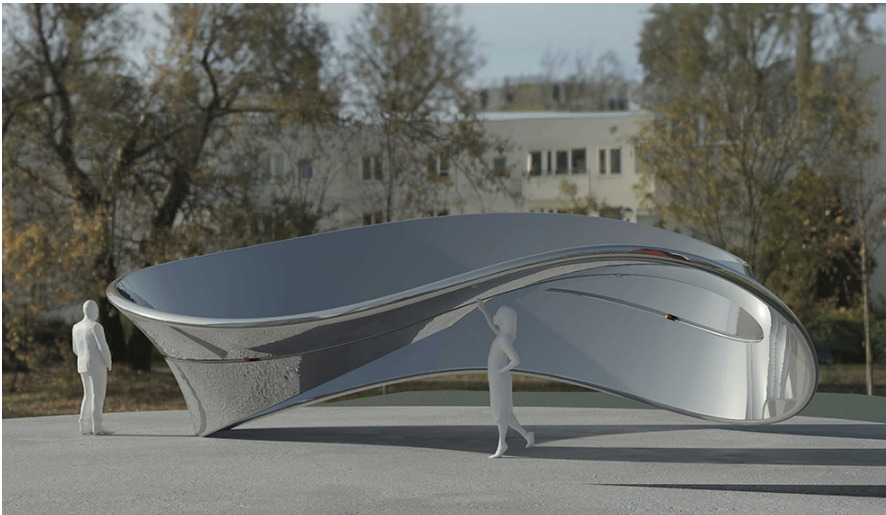
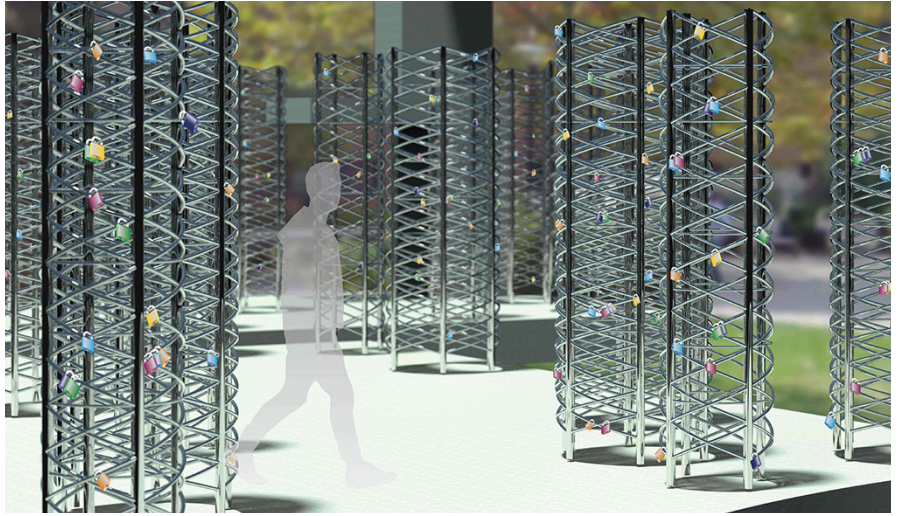



NYC Design Week Event Metaproject 13

Metaproject show at the International Contemporary Furniture Fair





NYC Design Week Event Metaproject 13

Metaproject show as a result of the collaboration with Lazzoni at the International Contemporary Furniture Fair







Communications 2023

Communications

Title	Information	Impact
Facebook	Managed by Jennifer Whitlock	• 5,500+ followers
Google Arts & Culture	Managed by Jennifer Whitlock	• People from 102 countries are viewing the collection 3182x/month (average).
Instagram	Managed by Jennifer Whitlock	• 32,900+ followers
Letters from the Director	Director's Letters provide essential updates from the Vignelli Center, keeping friends, associates informed and connected. They are crucial for nurturing existing relationships and welcoming new members, acting as a bridge that supports collaboration, business growth, and overall success.	• Seasonal—4x yearly • Additional announcements

Mail Chimp

Email marketing platform
managed by Josh Owen

• 5k subscribers

Pinterest

Managed by Jennifer Whitlock

• 15k impressions

Tumblr

Managed by Jennifer Whitlock

• 10,033 followers

Twitter

Managed by Jennifer Whitlock

• 5,367 followers

YouTube Channel

Managed by Jennifer Whitlock

• 14,000 views

EXIT



4

5

6

7

8

9

10

11

12

13



Initiatives 2023

Initiatives 2023

Title	Information	Impact
<p>Exhibition support: The Art of Medicine - Pharmaceutical Graphic Design from the RIT Archives 09 January 2023— 26 January 2023</p>	<p>This exhibit highlights a selection of pharmaceutical graphic design sourced from the Cary Graphic Arts Collection and the Vignelli Center for Design Studies Archive at Rochester Institute of Technology. The work exhibited is by notable graphic designers who include Will Burtin, Lester Beall, George Giusti, and Lella and Massimo Vignelli that date from the 1940s to the 2000s.</p>	
<p>Letter from the Director: Designer in Residence 11 January 2023</p>	<p>The Vignelli Center for Design Studies has appointed RZLBD (Reza Aliabadi) as the inaugural Vignelli Center Designer in Residence. This position was created to assist with an upcoming campus project to design and build a series of outdoor interactive exhibits tentatively titled the RIT Museumscape.</p> <p>As the first Vignelli Center Designer in Residence, RZLBD will provide research, design, and development assistance for the RIT Museumscape, which was conceived as part of President David Munson's vision for the future of the Rochester campus. RZLBD will work under the direction of Josh Owen, Vignelli Distinguished Professor of Design and director of the Vignelli Center.</p>	

Metaproject 13 head to NYC Design Week 2023

23 January 2023

Students who took part in Metaproject 13 will have their designs showcased as part of the 2023 New York City Design Week courtesy of their client, Lazzoni. In the fall, students spent the semester working to design seating solutions for the alumnus-owned international furniture company. All of the designs presented will be prototyped by Lazzoni, a first in Metaproject's history.

RIT appoints inaugural Vignelli Center Designer in Residence

24 January 2023

The Vignelli Center for Design Studies has appointed RZLBD (Reza Aliabadi) as the inaugural Vignelli Center Designer in Residence. This position was created to assist with an upcoming campus project to design and build a series of outdoor interactive exhibits tentatively titled the RIT Museumscape.

Vignelli Center Open House

25 January—26 January 2023

Open Houses event with 555+ artifacts from the Vignelli archives and Special Collections curated by Archivist Jennifer Whitlock with the Theme: Architecture. Open Houses provide a chance for anyone to come and interact with artifacts pulled from the vault without an appointment.

- 75 people over 2 days
- 6974 views on Instagram

Newsletter from the Director Happy New Year from the Vignelli Center

01 February 2023

Wishing everyone a happy new year and announcing upcoming Design Conversation lectures, Open Houses, and Beyond Fashion.

- 1602 opens
- 51 clicks

Design Conversations:

Debbie Millman

15 February 2023

Debbie Millman, a renowned creative force, acclaimed designer, author, educator, and host of the pioneering podcast “Design Matters.” President Emeritus of AIGA, co-founder of the first graduate branding program at SVA, and a driving force in brand consultancy. Her influence extends globally, championing design and social change through her work.

Vignelli Center Open House

22 March—23 March 2023

Open Houses event with 600+ artifacts from the Vignelli archives and Special Collections curated by Archivist Jennifer Whitlock with the Theme: Typography. Open Houses provide a chance for anyone to come and interact with artifacts pulled from the vault without an appointment.

- 83 People over 2 Days
- 5207 views on Instagram

Mitch Goldstein - How to Be a Design Student (and How to Teach Them)

7 March 2023

Goldstein, based in upstate New York, is a designer, artist, and educator at Rochester Institute of Technology. His work spans graphic design, furniture design, and design education, with articles in respected publications. His book, “How To Be A Design Student (And How to Teach Them),” offers invaluable insights for design students and professionals, drawing on his extensive teaching experience and real-world perspectives, enhancing both the student and professor’s design journey.

- 116 views on Youtube

Vignelli Center Open House

22 March—23 March 2023

Open Houses event with 600+ artifacts from the Vignelli archives and Special Collections curated by Archivist Jennifer Whitlock with the Theme: photography. Open Houses provide a chance for anyone to come and interact with artifacts pulled from the vault without an appointment.

- 83 People over 2 Days
- 5207 views on Instagram

Exhibition Designer

Elie Glyn

23 March 2023

Elie Glyn, a multidisciplinary creative professional with 12-plus years of experience creating exhibition designs for world-class museums, is speaking at RIT. His talk, “Designing the Exhibition Narrative,” is scheduled for 9:30 a.m. Thursday, March 23, in University Gallery.

Bruce Meader’s Week of Lunchtime Lectures

27 March—1 April 2023

Retired Rochester Institute of Technology Professor Bruce Ian Meader leads five enlightening typography and graphic design experiences at the Vignelli Center for Design Studies each day during the week of March 27th over the lunch hour. His interactive and informal talks take place in the Helen Hamlyn Trust Study Room on Level 4 of the Vignelli Center.

Design Conversations

John Edelman

27 April 2023

John Edelman is an experienced Board Member with a demonstrated history of working in the design industry. He is skilled in Modern Furniture, Retail, Textiles, Finish, and Renovation. As an independent consultant, his expertise in strategic growth is enhanced by an innate understanding of how people express themselves through consumer choices across a broad range of contract, trade, and lifestyle industries and product types.

- 179 views on Youtube

**Letter from the Director:
Design Week NYC 2023**

5 May 2023

Inviting RIT students, faculty and alumni as we celebrate the success of Metaproject 13 at New York Design Week.

- 1519 opens
- 3 clicks

**Letter from the Director:
Vignelli Center Spring Update**

10 May 2023

Recap of Spring semester including Design Conversation lectures, Meeting with Lady Helen Hamlyn, Bruce Meader Lectures, Intimate Vignelli, and visiting Lazzoni in Turkey for Metaproject 13

- 1466 opens
- 11 clicks

**Vignelli-inspired Regalia
to Debut at Commencement**

11 May 2023

Associate professor Melissa Dawson and Clare Maxwell '23 (industrial design) designed a cap and gown using fabric from the Vignelli archives for Josh Owen, director of the Vignelli Center for Design Studies, to wear at commencement.

Metaproject 13 Exhibition

20 May 2023

Students who took part in Metaproject 13 showcased their designs as part of the 2023 New York City Design Week courtesy of their client, Lazzoni.

**Design Students unveil
seating solutions at
NYC Design Week**

25 May 2023

Thirteen students worked with Lazzoni to produce contemporary chairs and sofas, with one of the designs now set to move into production with the high end furniture brand.

Vignelli Center 2023 Summer Design Workshop

3 June–10 June 2023

VCDS held a workshop inspired by the Vignelli Archives in partnership with the Corning Museum of Glass. A group of nine designers from various parts of the world created Lamp Shades that reflected the Vignelli's design principles in their own way. Using sketches and 3D prints from RIT's Fablab, Corning's master glass team brought each concept to life. The process was documented and put together into a book.

- 9 participants
- Archive tour and displays
- Corning partnership
- Youtube video
- Published book
- 10 3D printed prototypes
- 19 lamps by Master Glassblowers

Vignelli Center 2023 Summer Workshop Lamp Display

19 July 2023

This exhibition showcases twelve unique lamp designs created during the Vignelli Center for Design Studies 2023 Summer Workshop.

Letter from the Director: Welcome Back

21 August 2023

As the Fall 2023 Semester commences at RIT, the Vignelli Center extends a warm welcome. We're excited to recap a few of the highlights from summer 2023 and provide a sneak peek of our upcoming programming.

- 1592 opens
- 68 clicks

Design Conversations: Patricia Moore

6 September 2023

Moore is an internationally renowned gerontologist and designer, serving as a leading authority on consumer lifespan behaviors and requirements.

- Filled Wegmans auditorium

RIT News article: Looking for Inspiration? Try visiting the Vignelli Center for Design Studies Archives

13 September 2023

Interview in RIT News with Archivist Jennifer Whitlock

- 326 likes on Instagram

Vignelli Center

Open House

20 September—21 September 2023

Open Houses event with 430+ artifacts from the Vignelli archives and Special Collections curated by Archivist Jennifer Whitlock with the Theme: Design is One. Open Houses provide a chance for anyone to come and interact with artifacts pulled from the vault without an appointment.

- 165 People over 2 Days
- 5456 views on Instagram

Letter from the Director:

Fall Update

26 September 2023

As the Fall 2023 Semester commences at RIT, the Vignelli Center extends a warm welcome. We're excited to recap a few of the highlights from summer 2023 and provide a sneak peek of our upcoming programming.

- 1416 opens
- 50 clicks

Exhibition loan: Illuminating the Medieval and the Modern through Cultural Heritage Imaging: A Brief History of Innovation and Collaboration at RIT

26 September 2023

Modern imaging tools can help to illuminate—literally and figuratively—previously-unreadable artifacts, enabling scholars to unveil information and more fully understand and interpret these objects. This exhibition examines RIT's interdisciplinary, collaborative work in cultural heritage imaging, preservation, and research. By identifying scholarship, application, and use cases undertaken by faculty, researchers, and students over the past thirty years, the exhibit draws attention to methods of cultural heritage object analysis and, in particular, highlights a low-cost, low barrier-to-entry multispectral imaging system created by the Chester F. Carlson Center for Imaging Science and the Museum Studies Program.

Design Conversations:**Richard Poulin**

18 October 2023

Richard Poulin is a designer, educator, author, and artist. Throughout his career he has focused on a generalist approach to all aspects of design, including graphic, environmental, interior, and exhibition design, dividing his time between professional practice and academia.

Design Conversations:**Faride Mereb**

11 November 2023

Faride Mereb is a Venezuelan award-winning book designer, researcher, & educator based in New York City.

Beyond Fashion 2023

8 December 2023

Organized by students, this fashion show event weaves together a diverse collection of garments crafted by five local Rochester designers and wearables developed by students in RIT's metals and jewelry design and industrial design programs — all inspired by artifacts from the Vignelli archives. The theme for this year's event is, "The grid is everything."



1960S

UNIS

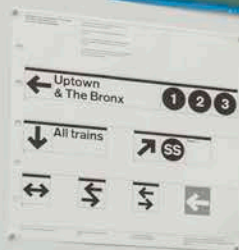
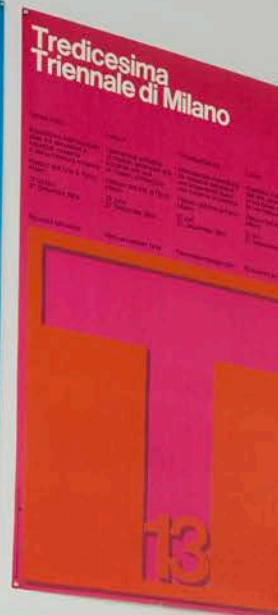
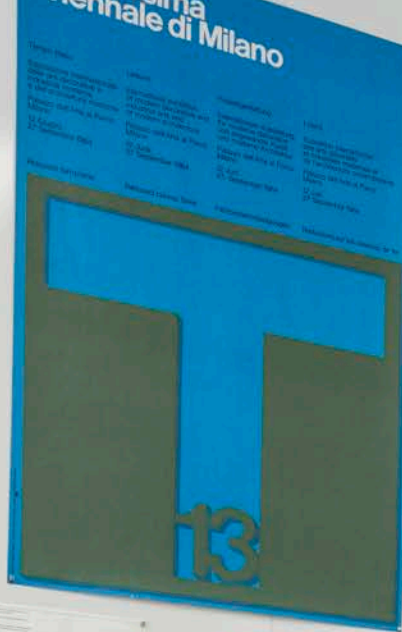

Piccolo Teatro di Milano



Piccolo Teatro di Milano

Il Gioco dei Potenti

da Enrico VIII Shakespeare in due giornate diretto da Giorgio Strehle

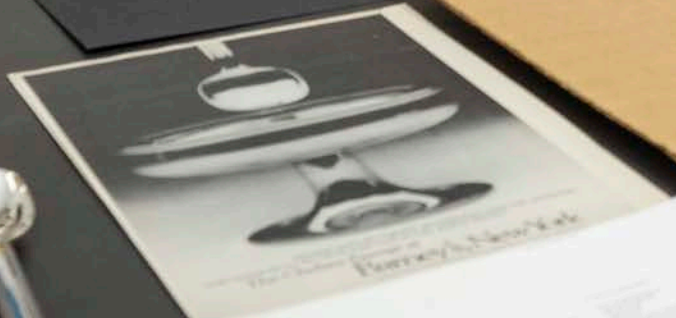



Vignelli Center Photos 2023



Vignelli Center for Design Studies

View from outside the Vignelli Center on RIT campus





Vignelli Center for Design Studies

View from outside the Vignelli Center on RIT campus





Vignelli Center for Design Studies Archives

Vignelli Clothing that inspired the first Beyond Fashion show



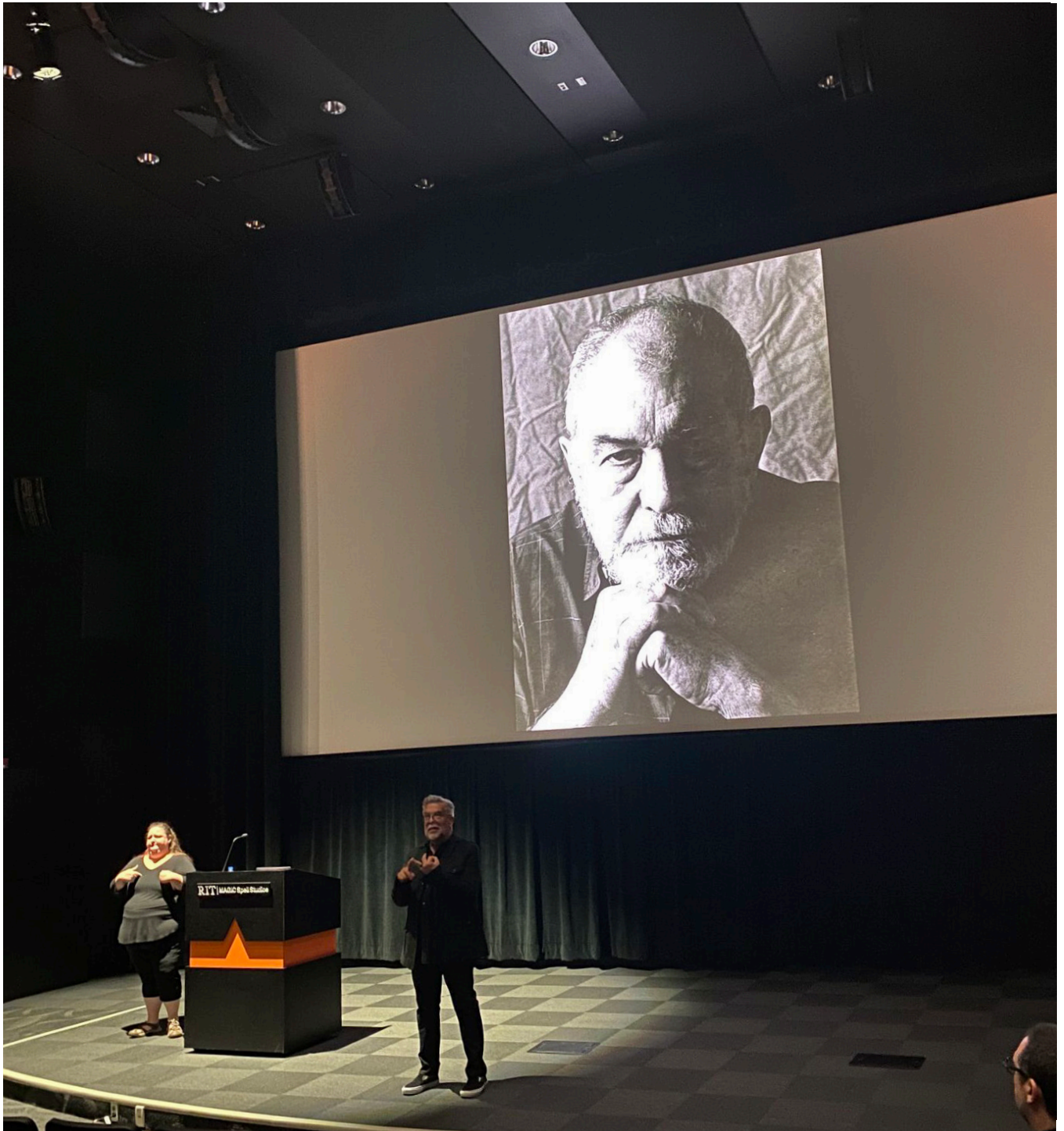

Designer Richard Poulin visits RIT

Poulin presented a talk on the career and impact of designer Rudolph de Harak



Vignelli-inspired Regalia to Debut at Commencement

Josh Owen, Melissa Dawson and Clare Maxwell stand beside the fabric from the Vignelli archives used to make regalia hat



Metaproject 14: A Chance for Students to Leave Their Mark on the RIT Campus Landscape

Instead of working with an outside client, students will work with RIT President David Munson to design concepts for a series of outdoor, hands-on museum installations for the university's Henrietta campus.





Dean Todd Jokl at the Metaproject show

College of Art and Design Dean, having a conversation at the Metaproject 13 show in New York City





RZLBD Appointed as the Inaugural Vignelli Center Designer In Residence

RZLBD (Reza Aliabadi) will provide research, design, and development assistance for the RIT Museumscape, which was conceived as part of President David Munson's vision for the future of the Rochester campus.





Beyond Fashion

The 2023 fashion show had the most RIT student involvement than ever in its history.
Photo by Georgia Pressley.





Summer Workshop Participants in the Ideation Stage

Participants of the workshop had access to the Vignelli Archives in the process of creating their final projects







Spotlight on Friends of the Vignelli Center



Qs and As by Richard Poulin, Design Conversation Lecturer

Collage by designer Richard Poulin on view at the Las Lagunas Art Gallery in Laguna Beach, California.



Core77 Design Awards 2023 Visual Communication Jury Member, Su Mathews Hale

The Core77 Design Awards juries comprise industry leading design experts from around the world. Vignelli Vision Group Member, Su Mathews Hale, was a juror for the 2023 Design Awards.



Alumna, Patricia Moore Presents Keynote Speech at UK Research and Innovation

Moore spoke on the topic of healthy aging based on her life's research.





Notes

Appendix

2023 Annual Report Colophon

Colophon

Direction

Josh Owen

Design

Liza Lennarz
Keli DiRisio

Production

Hannah Nettikadan
Jolie Greco

Photography

Alyssa Davis
Elizabeth Lamark
Liza Lennarz
The Corning Museum of Glass
The Vignelli Center for Design Studies

